

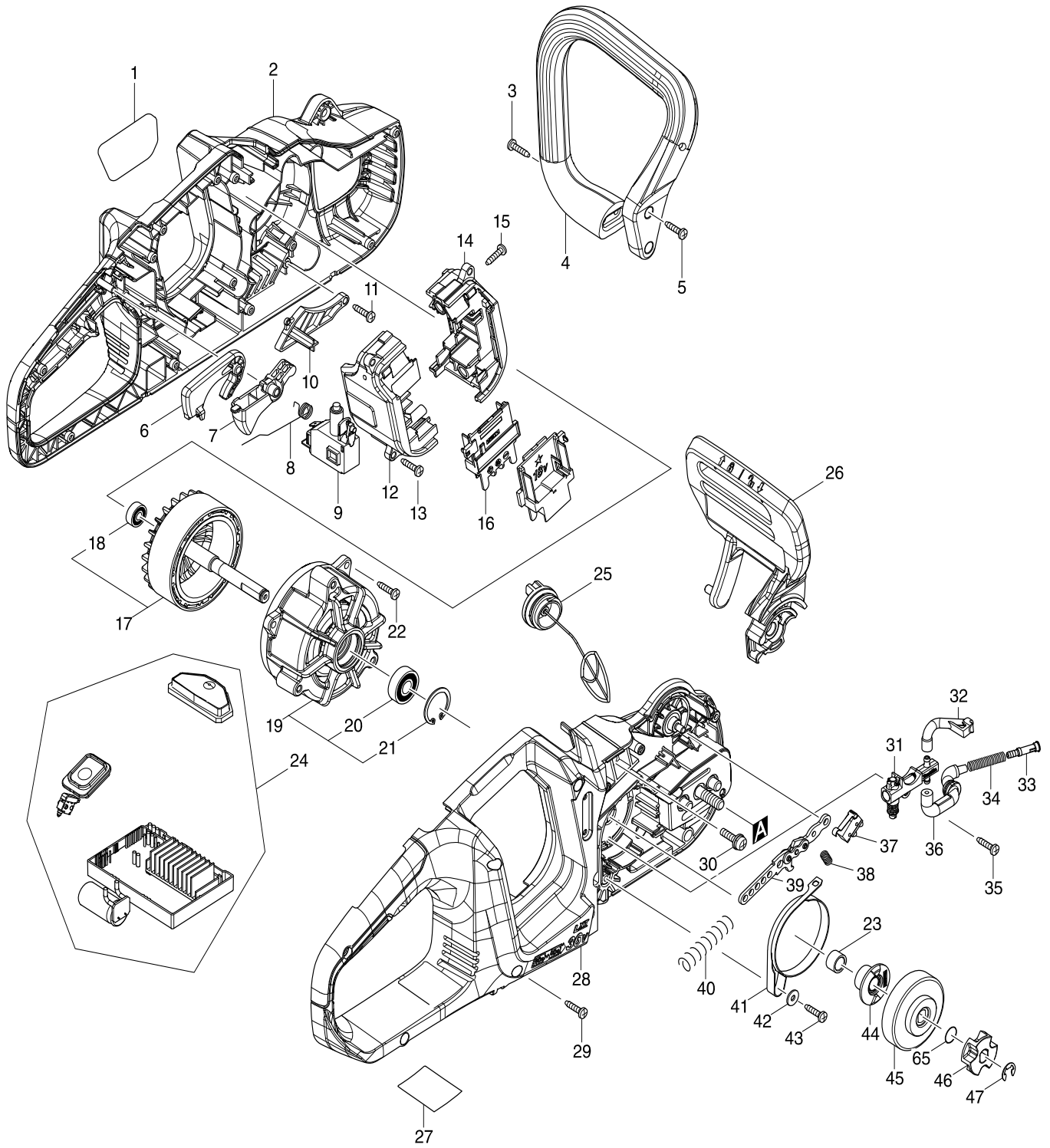

**XCU03**



Products with multiple versions are listed in subsiding order with the newest version on top not indented.

Section	Fig. No.	Part No.	Description	XCU03	Tech Bulletin	Notes
1 2		183F24-8	HOUSING SET	1		INC 28
1 3		266326-2	TAPPING SCREW 4X18	2		
1 4		457007-1	FRONT HANDLE	1		
1 5		266326-2	TAPPING SCREW 4X18	2		
1 6		457013-6	CATCH LEVER	1		
1 7		457006-3	SWITCH LEVER	1		
1 8		232318-3	TORSION SPRING 10	1		
1 9		650781-2	SWITCH C3JW-6B-P	1		
1 10		457010-2	HOUSING L COVER	1		
1 11		266326-2	TAPPING SCREW 4X18	1		
1 12		183F15-9	TERMINAL BOX SET	1		INC 14
1 13		266326-2	TAPPING SCREW 4X18	4		
1 14		183F15-9	TERMINAL BOX SET	1		INC 12
1 15		266326-2	TAPPING SCREW 4X18	2		
1 16		643874-2	TERMINAL	2		
1 17		519411-3	ROTOR ASSY	1		INC 18
1 18		211012-0	BALL BEARING 606ZZ	1		
1 18		210028-2	BALL BEARING 606ZZ	1		
1 19		592H45-5	STATOR ASSY	1		INC 20, 21
1 20		210059-1	BALL BEARING 6000DDW	1		
1 21		962105-3	RETAINING RING R-26	1		
1 22		266326-2	TAPPING SCREW 4X18	3		
1 23		257402-3	SLEEVE 10	1		
1 24		140G35-2	CONTROLLER COMPLETEQ	1		
1 24		144483-5	CONTROLLER COMPLETE	1		
1 25		168508-1	TANK CAP COMPLETE	1		
1 26		140A11-0	FRONT HAND GUARD COMPLETE	1		
1 26		144234-6	FRONT HAND GUARD COMPLETE	1		
1 28		183F24-8	HOUSING SET	1		INC 2
1 29		266326-2	TAPPING SCREW 4X18	8		
1 30		911233-1	PAN HEAD SCREW M5X20	3		
1 31		142156-4	OIL PUMP COMPLETE	1		
1 32		424904-6	CONNECTOR B	1		
1 33		452666-6	NIPPLE	1		
1 34		234207-8	COMPRESSION SPRING 6	1		

Products with multiple versions are listed in subsiding order with the newest version on top not indented.

Section	Fig. No.	Part No.	Description	XCU03	Tech Bulletin	Notes
1	35	266326-2	TAPPING SCREW 4X18	1		
1	36	424903-8	CONNECTOR A	1		
1	37	632H47-0	SWITCH UNIT	1		
1	38	231298-0	COMPRESSION SPRING 6	1		
1	39	163448-8	LINKPLATE COMPLETE	1		
1	40	232319-1	COMPRESSION SPRING 9	1		
1	41	345454-7	BRAKE BAND	1		
1	42	267195-4	FLAT WASHER 4	1		
1	43	266326-2	TAPPING SCREW 4X18	1		
1	44	221427-3	WORM GEAR	1		
1	45	161526-8	BRAKE DRUM COMPLETE	1		
1	46	221464-7	SPROCKET 6	1		3/8 PITCH (STANDARD)
1	46	198259-2	SPROCKET 6	1		1/4 PITCH (ACCESSORY)
1	47	961013-5	STOP RING E-7	1		
1	65	266326-2	O RING 10	4		

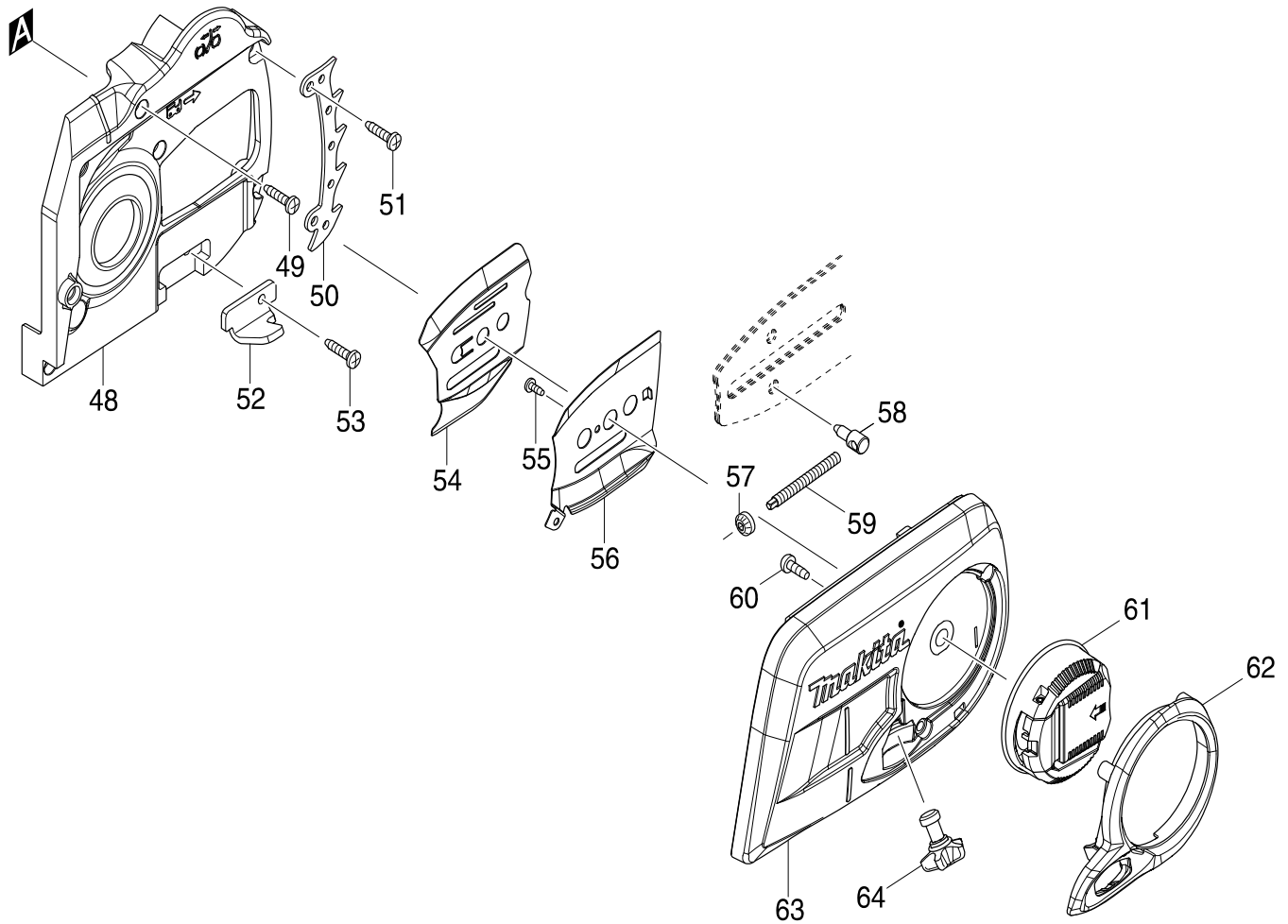

Products with multiple versions are listed in subsiding order with the newest version on top not indented.

Section	Fig. No.	Part No.	Description	XCU03	Tech Bulletin	Notes
2	48	457004-7	HOUSING R COVER	1		
2	49	266326-2	TAPPING SCREW 4X18	4		
2	50	347078-5	SPIKE BUMPER	1		
2	51	266326-2	TAPPING SCREW 4X18	2		
2	52	347079-3	CHAIN CATCHER	1		
2	53	266326-2	TAPPING SCREW 4X18	1		
2	54	346694-0	GUIDE PLATE ES	1		
2	55	266166-8	TAPPING SCREW CT 3X8	1		
2	56	346699-0	GUIDE PLATE CS	1		
2	57	227496-2	STRAIGHT BEVEL GEAR 14	1		
2	58	326310-0	ADJUST PIN	1		
2	59	326312-6	ADJUST SCREW	1		
2	60	266427-6	TAPPING SCREW 4X12	3		
2	61	142235-8	NUT COMPLETE	1		
2	62	454519-5	NUT COVER	1		
2	63	457000-5	SPROCKET COVER	1		
2	64	142288-7	WHEEL COMPLETE	1		

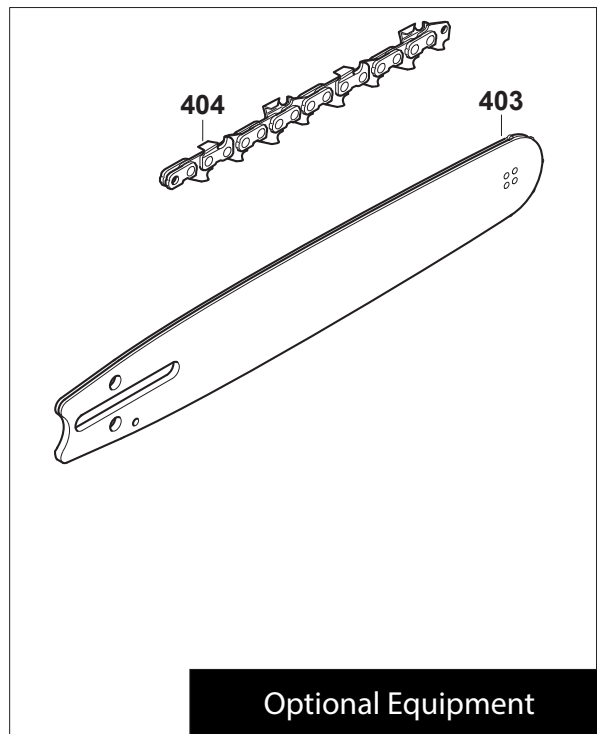
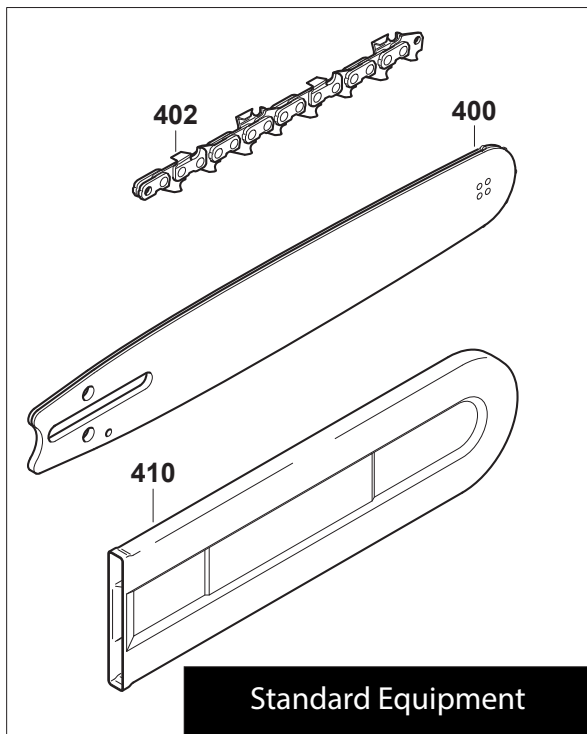

Products with multiple versions are listed in subsiding order with the newest version on top not indented.

Section	Fig. No.	Part No.	Description	XCU03	Tech Bulletin	Notes
3	400	165246-6	GUIDE BAR, 14" 3/8 .043	1		Standard Equipment
3	402	196741-5	SAW CHAIN SET 14" 3/8 .043	1		Standard Equipment
3	403	165245-8	GUIDE BAR 12" 3/8 .043	1		
3	403	163150-3	GUIDE BAR 12" 3/8 .050	1		
3	403	165201-8	GUIDE BAR 14" 3/8 .050	1		
3	403	165247-4	GUIDE BAR 16" 3/8 .043	1		
3	403	442-040-661	GUIDE BAR 16" 3/8 .050	1		
3	404	531-291-646	SAW CHAIN SET 12" 3/8 .043	1		
3	404	196519-6	SAW CHAIN SET 12" 3/8 .050	1		
3	404	196207-5	SAW CHAIN SET 14" 3/8 .050	1		
3	404	196742-3	SAW CHAIN SET 16" 3/8 .043	1		
3	404	196208-3	SAW CHAIN SET 16" 3/8 .050	1		
3	410	419242-9	CHAIN PROTECTOR 14-16"	1		