



## **PARTS BREAKDOWN**

**EX2650LH**

**CS-246.4 C**

**CS-246.4CBC**

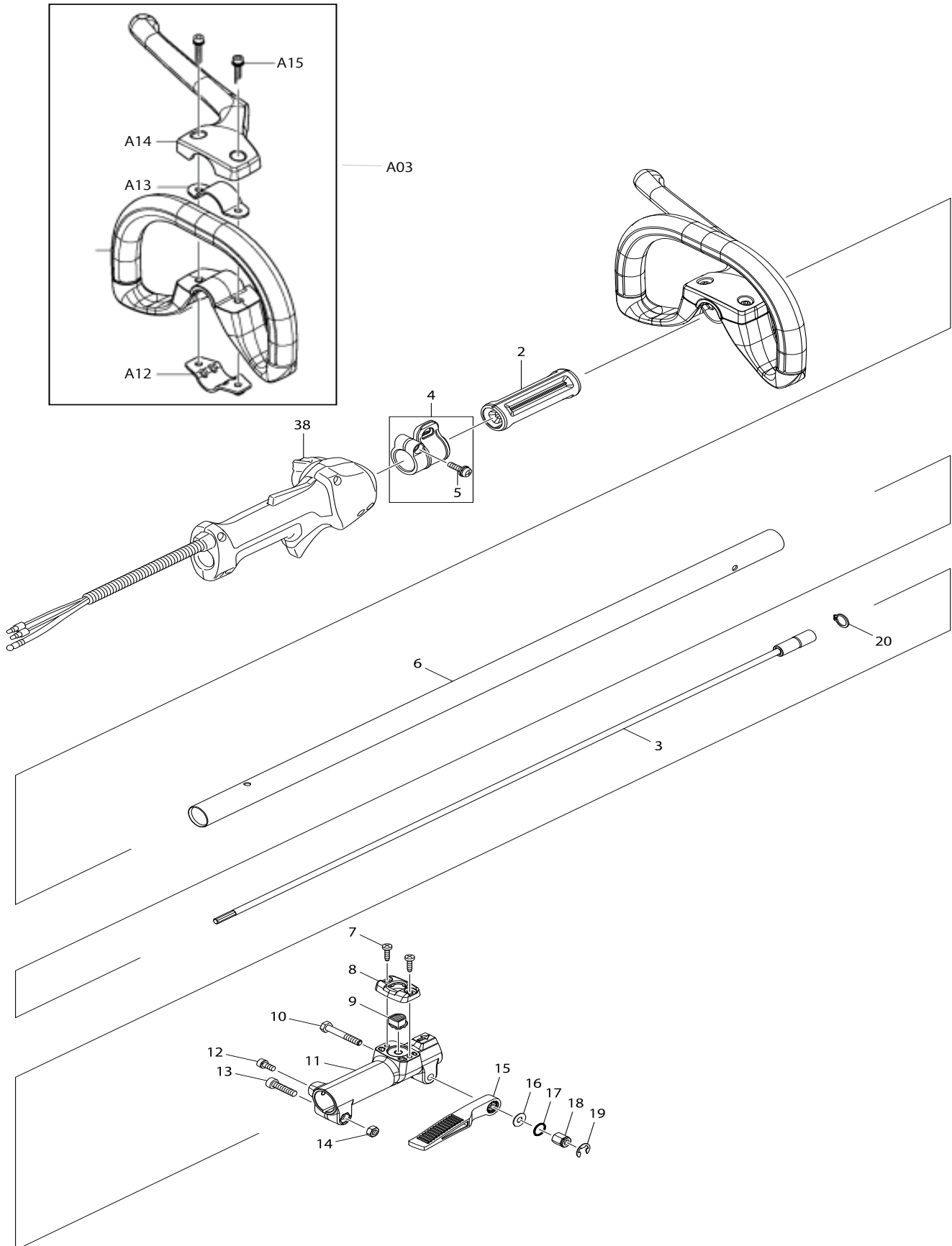

**EX2650LH**  
**CS-246.4 C, CS-246.4CBC**

**1**

**Main Pipe Assembly, Handle**

Products with multiple versions are listed in subsiding order with the newest version on top not indented.

Section	Fig. No.	Part No.	Description	EX2650LH	CS-246.4C	CS-246.4C/BC	Tech Bulletin	Notes
1	2	451601-1	SPACER	1	1	1		
1	3	141238-9	SHAFT COMPLETE	1	1	1		
1	4	195143-2	HANGER SET	1	1	1		INC. 5
1	5	911233-1	PAN HEAD SCREW	1	1	1		
1	6	141008-6	SHAFT PIPE COMPLETE	1	1	1		
1	7	266034-5	TAPPING SCREW	2	2	2		
1	8	452840-6	RELEASE BUTTON COVER	1	1	1		
1	9	452839-1	RELEASE BUTTON	1	1	1		
1	10	265596-0	HEX. SOCKET HEAD BOLT	1	1	1		
1	11	318750-6	JOINT PIPE	1	1	1		
1	12	922211-6	HEX. SOCKET HEAD BOLT	1	1	1		
1	13	922342-1	HEX. SOCKET HEAD BOLT	1	1	1		
1	14	931302-2	HEXAGONAL NUT	1	1	1		
1	15	272268-0	LEVER	1	1	1		
1	16	253332-6	THIN WASHER	1	1	1		
1	17	213105-9	O RING	1	1	1		
1	18	252159-1	HEXAGONAL NUT	1	1	1		
1	19	259054-6	STOP RING	1	1	1		
1	20	961052-5	RETAINING RING	1	1	1		
1	38	125776-9	CONTROL LEVER ASS'Y	1	1	1		INC. 39-55
1	A03	195515-1	LOOP HANDLE SET	1	1	1		
1	A12	346467-1	CLAMP	1	1	1		
1	A13	346468-9	CLAMP	1	1	1		
1	A14	452842-2	CLAMP COVER	1	1	1		
1	A15	922244-1	H.S.H.BOLT WITH WG	2	2	2		

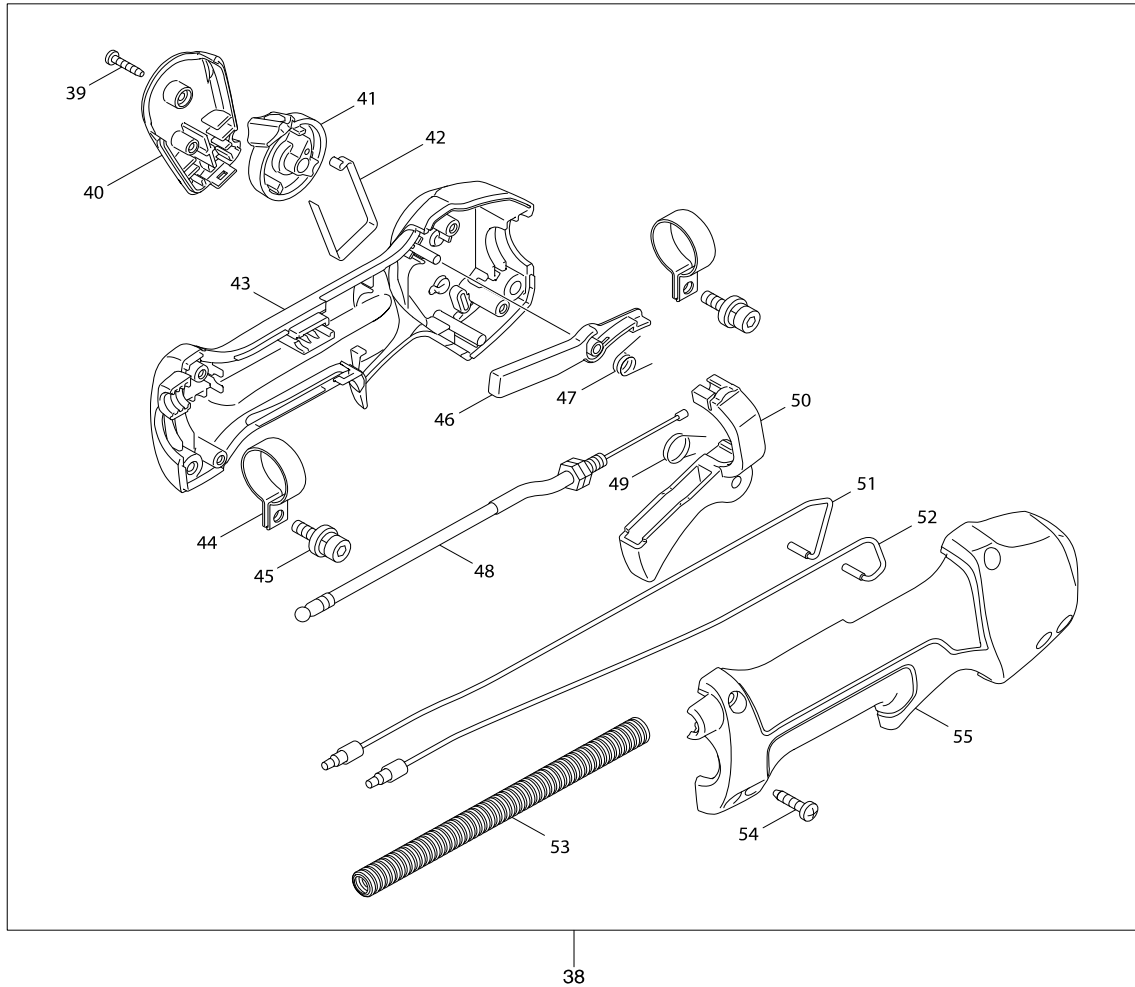

**EX2650LH**  
**CS-246.4 C, CS-246.4CBC**

**2** Throttle Handle

Products with multiple versions are listed in subsiding order with the newest version on top not indented.

Section	Fig. No.	Part No.	Description	EX2650LH	CS-246.4C	CS-246.4C/BC	Tech Bulletin	Notes
2	38	125776-9	CONTROL LEVER ASS'Y	1	1	1		INC. 39-55
2	39	266130-9	TAPPING SCREW BIND TP	1	1	1		
2	40	451595-0	SWITCH COVER	1	1	1		
2	41	451594-2	SWITCH LEVER	1	1	1		
2	42	232251-9	LEAF SPRING	1	1	1		
2	43	188832-6	LEVER CASE, SET	1	1	1		INC. 55
2	44	346248-3	CLAMP	2	2	2		
2	45	922218-2	H.S.H.BOLT WITH WR	2	2	2		
2	46	451593-4	LOCK LEVER	1	1	1		
2	47	233541-3	TORSION SPRING	1	1	1		
2	48	168571-4	CONTROL CABLE	1	1	1		
2	49	233540-5	TORSION SPRING	1	1	1		
2	50	451592-6	THROTTLE LEVER	1	1	1		
2	51	638714-7	LEAD UNIT	1	1	1		
2	52	638713-9	LEAD UNIT	1	1	1		
2	53	452071-7	CORRUGATED TUBE	1	1	1		
2	54	266326-2	SCREW	4	4	4		
2	55	188832-6	LEVER CASE, SET	1	1	1		INC. 43

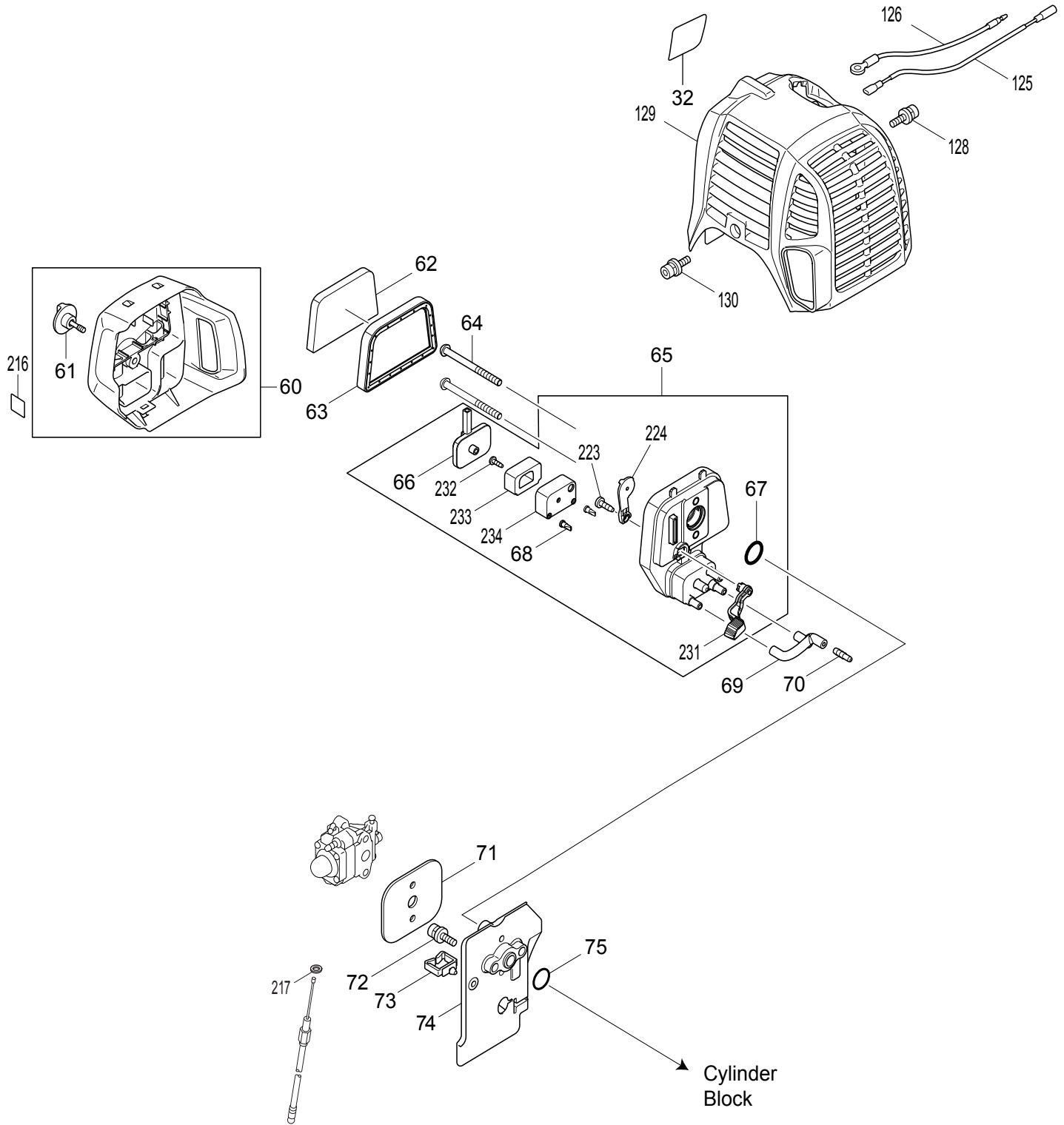

# EX2650LH CS-246.4 C, CS-246.4CBC

# 3

## Insulator, Cleaner Base, Engine Cover

Products with multiple versions are listed in subsiding order with the newest version on top not indented.

Section	Fig. No.	Part No.	Description	EX2650LH	CS-246.4C	CS-246.4C/BC	Tech Bulletin	Notes
3	60	123499-3	AIR CLEANER COVER ASSY.	1	1	1	B1277	INC. 61
3	60	126202-1	AIR CLEANER COVER ASSY.	1	1	1		INC. 61
3	61	265791-2	THUMB SCREW	1	1	1		
3	62	443171-4	ELEMENT AIR CLEANER	1	1	1		
3	63	443169-1	ELEMENT AIR CLEANER	1	1	1		
3	64	266618-9	H.S.BUTTON HEAD BOLT	2	2	2		
3	65	123501-2	AIR CLEANER PLATE ASS'Y	1	1	1	B1277	INC. 66-68, 223, 224, 231-234
3	65	126198-6	AIR CLEANER PLATE ASS'Y	1	1	1		INC. 66-68, 223, 224, 231-234
3	66	162346-3	SEPARATOR PLATE	1	1	1		
3	67	213540-1	O RING	1	1	1		
3	68	424316-3	CHECK VALVE	2	2	2		
3	69	422099-9	PIPE	1	1	1		
3	70	325665-0	JOINT PIPE	1	1	1		
3	71	442153-3	CARBURETOR GASKET	1	1	1		
3	72	266787-6	H.S.H.BOLT	2	2	2		
3	73	451825-9	CLAMP	1	1	1		
3	74	451729-5	INSULATOR	1	1	1		
3	75	213547-7	O-RING	1	1	1		
3	125	638707-4	LEAD UNIT	1	1	1		
3	126	638708-2	LEAD UNIT	1	1	1		
3	128	922218-2	H.S.H.BOLT WITH WR	1	1	1		
3	129	453266-5	CYLINDER COVER	1				
3	129	453569-7	CYLINDER COVER		1	1		
3	130	922218-2	H.S.H.BOLT WITH WR	1	1	1		
3	216	800F73-7	INDICATION LABEL	1	1	1		
3	217	941152-7	FLAT WASHER	1	1	1		
3	223	266427-6	TAPPING SCREW	1	1	1		
3	224	452219-1	CHOKE PLATE	1	1	1		
3	231	452220-6	CHOKE LEVER	1	1	1		
3	232	266007-8	TAPPING SCREW BIND	1	1	1		
3	233	352020-3	SEPARATOR MESH	1	1	1		
3	234	453865-3	SEPARATOR CASE	1	1	1		

### Included in Short Block Assembly Fig. No. 236.

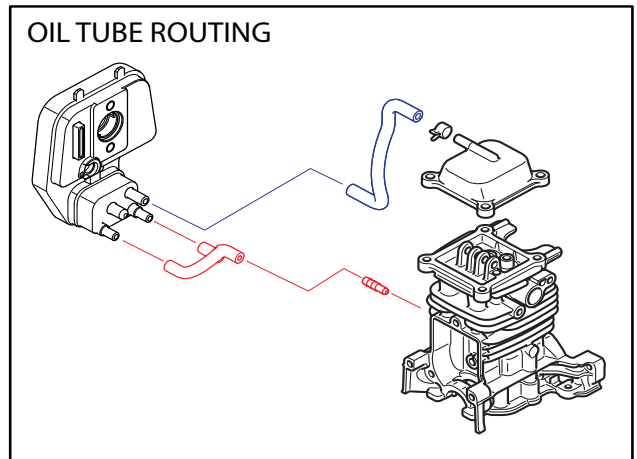
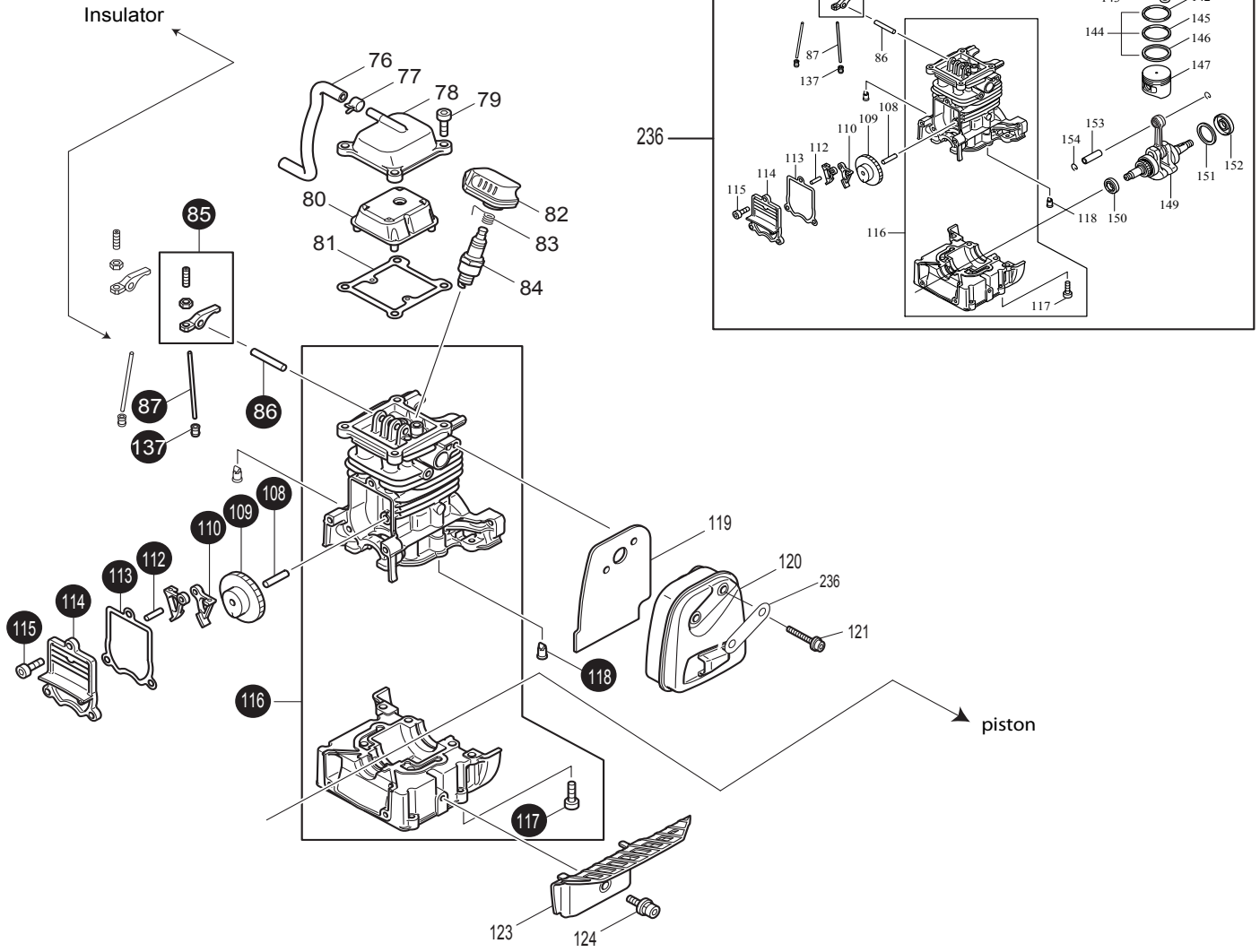



# EX2650LH CS-246.4 C, CS-246.4CBC

# 4

## Piston, Cylinder, Muffler, Oil Tank

Products with multiple versions are listed in subsiding order with the newest version on top not indented.

Section	Fig. No.	Part No.	Description	EX2650LH	CS-246.4C	CS-246.4C/BC	Tech Bulletin	Notes
4	76	422109-2	BREATHER PIPE	1	1	1		
4	77	345918-1	HOSE CLAMP	1	1	1		
4	78	318745-9	ROCKER COVER OUTER	1	1	1		
4	79	922222-1	HEX. SOCKET HEAD BOLT	4	4	4		
4	80	453860-3	ROCKER COVER INNER	1	1	1		
4	81	162304-9	ROCKER COVER GASKET	1	1	1		
4	82	424302-4	PLUG CAP	1	1	1		
4	83	324891-8	PLUG CAP SPRING	1	1	1		
4	84	168534-0	SPARK PLUG	1	1	1		NGK CMR4A .030
4	85	125554-7	ROCKER ARM ASS'Y	2	2	2		
4	86	256200-2	PIN	1	1	1		
4	87	256865-0	ROD	2	2	2		
4	88	325668-4	SPRING RETAINER	2	2	2		
4	108	268238-5	PIN	1	1	1		
4	108	592-35005-01	PIN	1	1	1		
4	109	125552-1	CAM GEAR ASS'Y	1	1	1		
4	110	313169-4	CAM LIFTER	2	2	2		
4	112	268239-3	PIN	1	1	1		
4	112	592-35006-00	PIN	1	1	1		
4	113	162274-2	CAM GEAR COVER GASKET	1	1	1		
4	114	318443-5	CAMGEAR COVER	1	1	1		
4	115	922222-1	HEX. SOCKET HEAD BOLT	3	3	3		
4	116	135478-9	CYLINDER BLOCK SET	1	1	1		INC. 88, 117, 118
4	117	922222-1	HEX. SOCKET HEAD BOLT	6	6	6		
4	118	424201-0	CHECK VALVE	2	2	2		
4	119	346331-6	MUFFLER GASKET	1	1	1		
4	120	168554-4	EXHAUST MUFFLER	1	1	1		
4	121	266440-4	HEX. SOCKET HEAD BOLT	2	2	2		
4	123	451731-8	MUFFLER PLATE	1	1	1		
4	124	922218-2	H.S.H.BOLT WITH WR	1	1	1		
4	137	424200-2	SPACER	2	2	2		
4	138	234108-0	COMPRESSION SPRING	2	2	2		
4	140	325669-2	EXHAUST VALVE	1	1	1		
4	143	325670-7	INTAKE VALVE	1	1	1		
4	142	257298-2	PISTON RING TOP	1	1	1		USE PISTON RING SET

Products with multiple versions are listed in subsiding order with the newest version on top not indented.

Section	Fig. No.	Part No.	Description	EX2650LH	CS-246.4C	CS-246.4C/BC	Tech Bulletin	Notes
4	144	195145-8	PISTON RING SET	1	1	1		
4	145	257299-0	PISTON RING SECOND	1	1	1		USE PISTON RING SET
4	146	257300-1	PISTON RING BOTTOM	1	1	1		USE PISTON RING SET
4	147	318441-9	PISTON	1	1	1		
4	149	126359-8	CRANKSHAFT ASS'Y	1	1	1		
4	149	126204-7	CRANKSHAFT ASS'Y	1	1	1		
4	150	213148-1	OIL SEAL	1	1	1		
4	151	267400-9	FLAT WASHER	1	1	1		
4	152	213147-3	OIL SEAL	1	1	1		
4	153	257781-9	PISTON PIN	1	1	1		
4	154	233976-8	CLIP	2	2	2		
4	236	135668-4	SHORT BLOCK ASSEMBLY	1	1	1		

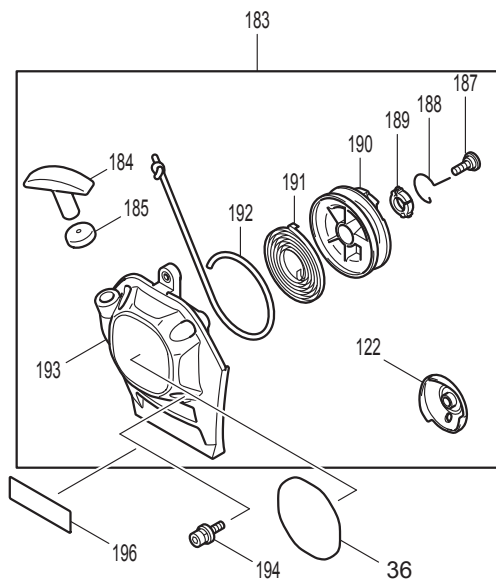
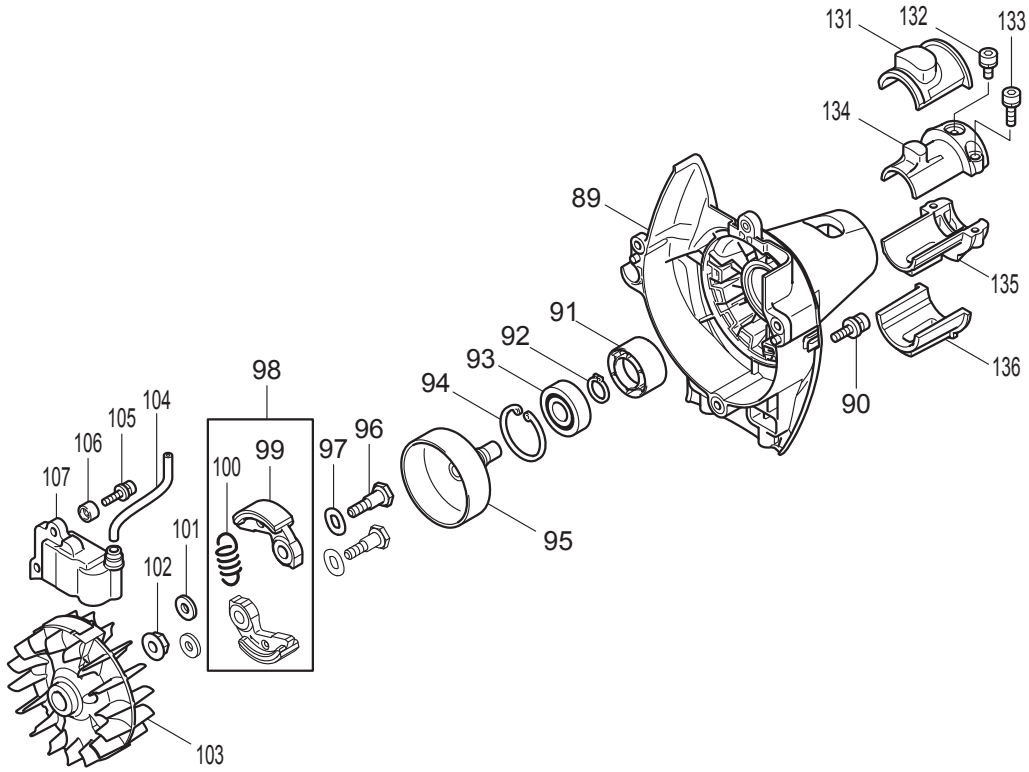

Products with multiple versions are listed in subsiding order with the newest version on top not indented.

Section	Fig. No.	Part No.	Description	EX2650LH	CS-246.4C	CS-246.4C/BC	Tech Bulletin	Notes
5	89	451735-0	CLUTCH CASE	1	1	1		
5	90	922228-9	H.S.H.BOLT WITH WR	3	3	3		
5	91	450569-8	SPACER	1	1	1		
5	92	961052-5	RETAINING RING	1	1	1		
5	93	211129-9	BALL BEARING	1	1	1		
5	93	210111-5	BALL BEARING	1	1	1		
5	94	962151-6	RETAINING RING	1	1	1		
5	95	161588-6	CLUTCH DRUM	1	1	1		
5	95	165704-2	CLUTCH DRUM	1	1	1		
5	96	266864-4	SHOULDER HEX. BOLT	2	2	2		
5	97	267817-6	WASHER	2	2	2		
5	98	126135-0	CLUTCH ASSY.	1	1	1		INC. 99-100
5	99	168498-8	CLUTCH SHOE	2	2	2		
5	100	231881-3	TENSION SPRING	1	1	1		
5	101	267812-6	WASHER	2	2	2		
5	102	264039-9	NUT	1	1	1		
5	103	318569-3	FLYWHEEL	1	1	1		
5	104	444021-6	TUBE	1	1	1		
5	105	266602-4	HEX. SOCKET HEAD BOLT	2	2	2		
5	106	452049-0	SPACER	2	2	2		
5	107	168559-4	IGNITION COIL	1	1	1		
5	122	168483-1	PULLEY STARTER	1	1	1		
5	131	424082-2	VIBRATION DAMPER	1	1	1		
5	132	922211-6	HEX. SOCKET HEAD BOLT	1	1	1		
5	133	922226-3	HEX. SOCKET HEAD BOLT	2	2	2		
5	134	318249-1	PIPE BRACKET	1	1	1		
5	135	318250-6	PIPE BRACKET	1	1	1		
5	136	424083-0	VIBRATION DAMPER	1	1	1		
5	183	195308-6	RECOIL STARTER SET	1	1	1		
5	184	424319-7	STARTER KNOB	1	1	1		
5	185	424359-5	DAMPER	1	1	1		
5	187	266585-8	TAPPING SCREW	1	1	1		
5	188	325923-4	SWING ARM	1	1	1		
5	189	451938-6	COLLAR	1	1	1		
5	190	451937-8	REEL	1	1	1		

**EX2650LH**  
**CS-246.4 C, CS-246.4CBC**

**5**

**Clutch, Ignition, Starter**

Products with multiple versions are listed in subsiding order with the newest version on top not indented.

Section	Fig. No.	Part No.	Description	EX2650LH	CS-246.4C	CS-246.4C/BC	Tech Bulletin	Notes
5	191	232258-5	SPIRAL SPRING	1	1	1		
5	192	444023-2	STARTER ROPE	1	1	1		
5	193	451733-4	STARTER CASE	1	1	1		
5	194	922223-9	H.S.H.BOLT WITH WR	4	4	4		

 Included in Short Block Assembly Fig. No. 236.

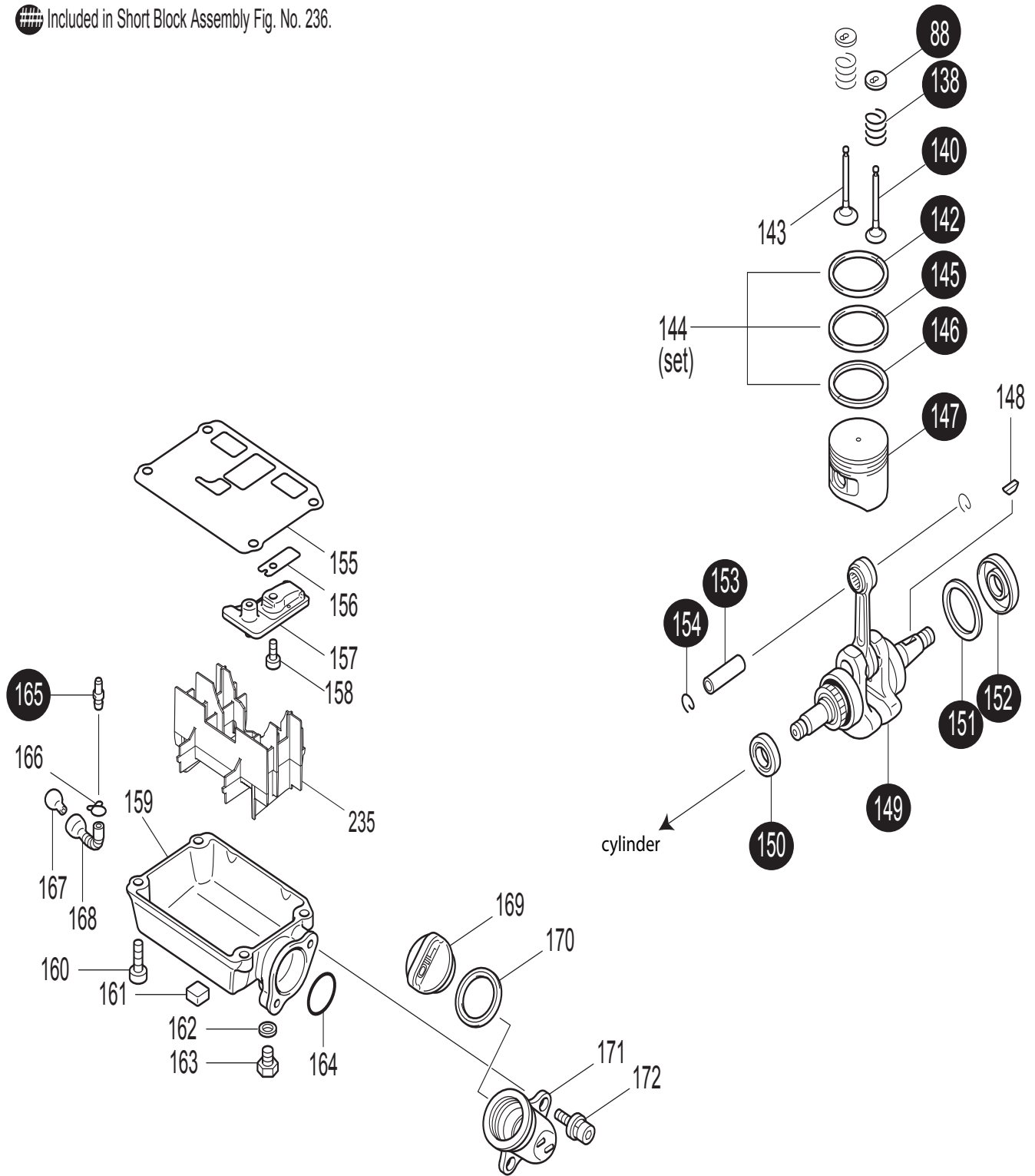

# EX2650LH CS-246.4 C, CS-246.4CBC

# 6

## Oil Tank, Crankshaft, Piston, Valves

Products with multiple versions are listed in subsiding order with the newest version on top not indented.

Section	Fig. No.	Part No.	Description	EX2650LH	CS-246.4C	CS-246.4C/BC	Tech Bulletin	Notes
6	88	325668-4	SPRING RETAINER	2	2	2		
6	138	234108-0	COMPRESSION SPRING	2	2	2		
6	140	325669-2	EXHAUST VALVE	1	1	1		
6	142	257298-2	PISTON RING TOP	1	1	1		USE PISTON RING SET
6	143	325670-7	INTAKE VALVE	1	1	1		
6	144	195145-8	PISTON RING SET	1	1	1		
6	145	257299-0	PISTON RING SECOND	1	1	1		USE PISTON RING SET
6	146	257300-1	PISTON RING BOTTOM	1	1	1		USE PISTON RING SET
6	147	318441-9	PISTON	1	1	1		
6	148	254040-2	WOODRUFF KEY	1	1	1		
6	149	126204-7	CRANKSHAFT ASS'Y	1	1	1		INC. 150-152
6	150	213148-1	OIL SEAL	1	1	1		
6	151	267400-9	FLAT WASHER	1	1	1		
6	152	213147-3	OIL SEAL	1	1	1		
6	153	257781-9	PISTON PIN	1	1	1		
6	154	233976-8	CLIP	2	2	2		
6	155	162345-5	OIL CASE GASKET	1	1	1		
6	156	592-15010-00	LEAD VALVE	1	1	1		
6	157	318910-0	RETAINER PLATE	1	1	1		
6	158	922112-8	HEX. SOCKET HEAD BOLT	1	1	1		
6	159	318588-9	OIL CASE	1	1	1		
6	160	922222-1	HEX. SOCKET HEAD BOLT	4	4	4		
6	161	424344-8	DAMPER	1	1	1		
6	162	346305-7	GASKET	1	1	1		
6	163	266611-3	HEXAGON BOLT	1	1	1		
6	164	213548-5	O-RING	1	1	1		
6	165	325665-0	JOINT PIPE	1	1	1		
6	166	282020-8	HOSE CLAMP	1	1	1		
6	167	325666-8	OIL WEIGHT	1	1	1		
6	168	424301-6	OIL TUBE	1	1	1		
6	169	452047-4	OIL CAP	1	1	1		
6	170	424343-0	GASKET	1	1	1		
6	170	021-32299-90	GASKET	1	1	1		
6	171	452048-2	OIL PIPE	1	1	1		
6	172	922218-2	H.S.H.BOLT WITH WR	2	2	2		
6	235	453862-9	OIL CASE PLATE	1	1	1		

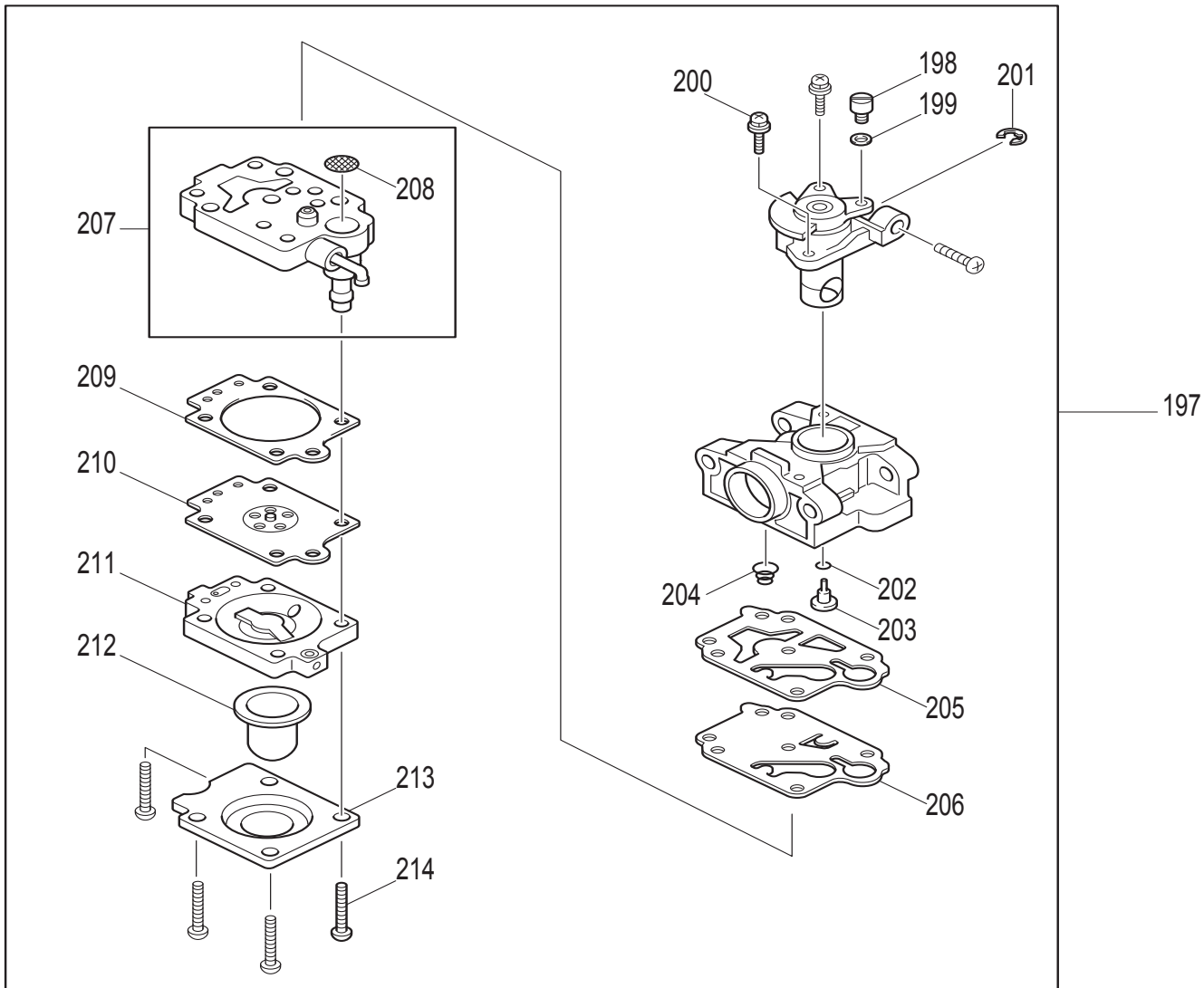
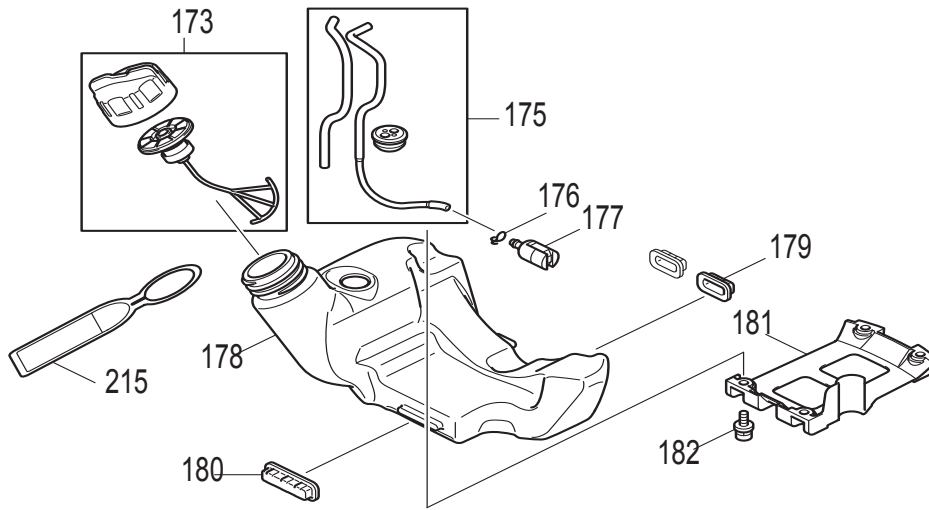



Products with multiple versions are listed in subsiding order with the newest version on top not indented.

Section	Fig. No.	Part No.	Description	EX2650LH	CS-246.4C	CS-246.4C/BC	Tech Bulletin	Notes
7	173	125728-0	FUEL TANK CAP ASSEMBLY	1	1	1		
7	174	451739-2	FUEL TANK CAP	1	1	1		
7	175	168775-8	TUBE COMPLETE	1	1	1		
7	175	168755-4	TUBE COMPLETE	1	1	1		
7	176	282020-8	HOSE CLAMP	1	1	1		
7	177	163518-3	GASOLIN FILTER	1	1	1		
7	178	123419-7	FUEL TANK	1	1	1		
7	178	454010-3	FUEL TANK	1	1	1		
7	178	452249-2	FUEL TANK	1	1	1		
7	179	424080-6	VIBRATION DAMPER	2	2	2		
7	180	424081-4	VIBRATION DAMPER	1	1	1		
7	181	451737-6	TANK GUARD	1	1	1		
7	182	922218-2	H.S.H.BOLT WITH WR	4	4	4		
7	215	810455-9	CAUTION PLATE	1	1	1		
7	197	168762-7	CARBURETOR	1	1	1		
7	198	325922-6	SWIVEL	1	1	1		
7	199	413140-9	WASHER	1	1	1		
7	200	266581-6	PAN HEAD SCREW	2	2	2		
7	201	257964-1	STOP RING	1	1	1		
7	202	213538-8	O RING	1	1	1		
7	203	325985-2	JET	1	1	1		
7	204	234183-6	CONICAL COMPRESSION SPRING	1	1	1		
7	205	442155-9	PUMP GASKET	1	1	1		
7	206	168575-6	PUMP DIAPHRAGM	1	1	1		
7	207	141737-1	PUMP BODY	1	1	1		
7	208	352010-6	INLET SCREEN	1	1	1		
7	209	442154-1	METERING DIAPHRAGM GASKET	1	1	1		
7	210	168620-7	METERING DIAPHRAGM	1	1	1		
7	211	140438-8	AIR PURGE BODY ASS'Y	1	1	1		
7	212	424314-7	PRIMER PUMP	1	1	1		

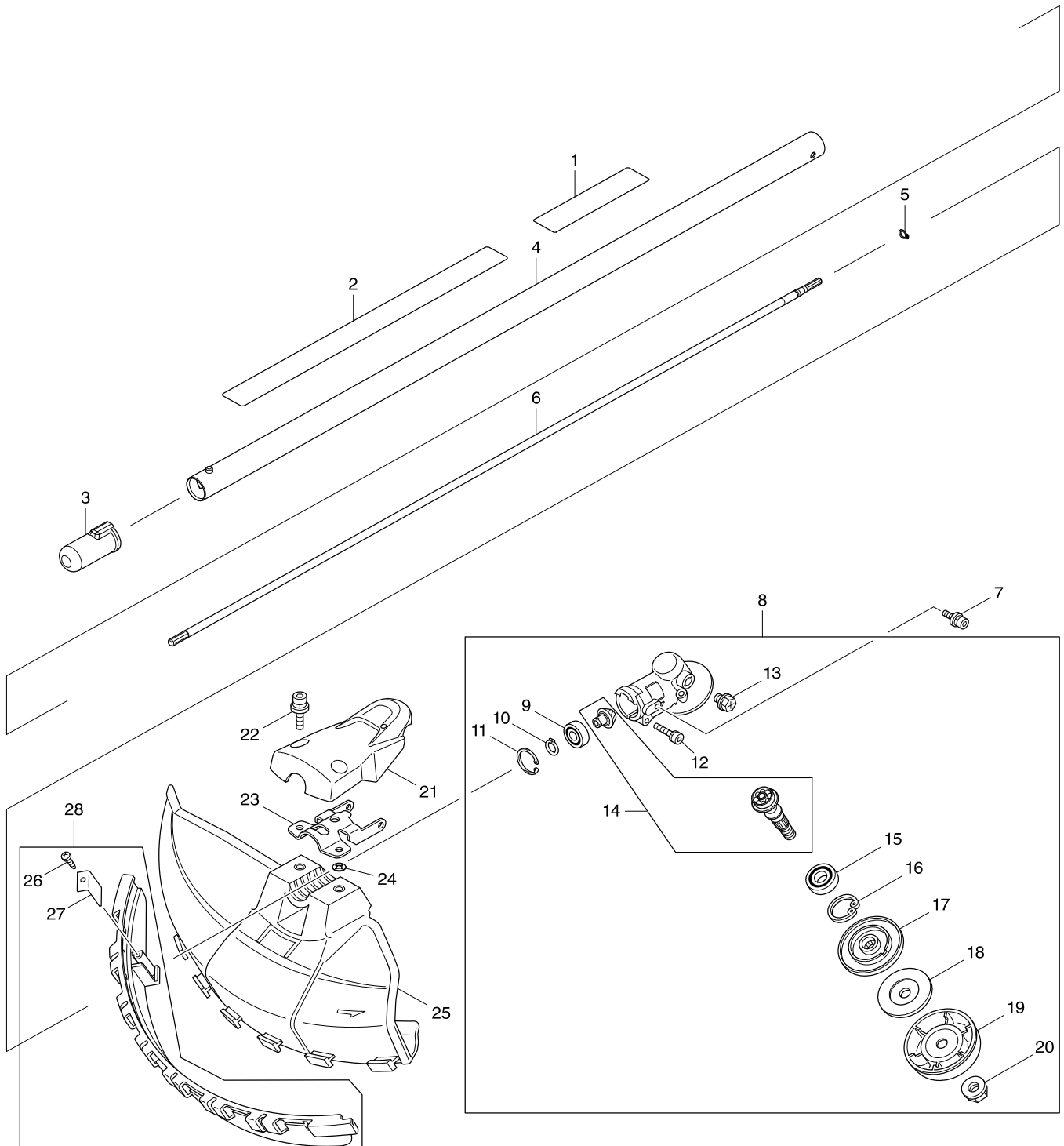

# EX2650LH CS-246.4 C, CS-246.4CBC

# 8

## BC-CS Brushcutter Attachment

Products with multiple versions are listed in subsiding order with the newest version on top not indented.

Section	Fig. No.	Part No.	Description	EX2650LH	CS-246.4C	CS-246.4C/BC	Tech Bulletin	Notes
8	3	424434-7	CAP, BC-CS			1		
8	4	141010-9	SHAFT PIPE COMPLETE, BC-CS			1		
8	5	961003-8	RETAINING RING, BC-CS			1		
8	6	326088-5	SHAFT, BC-CS			1		
8	7	922218-2	H.S.H.BOLT WITH WR			2		
8	8	126264-9	GEAR CASE ASS'Y			1		
8	8	126102-5	GEAR CASE ASS'Y			1		
8	9	210049-4	BALL BEARING			1		
8	10	961005-4	RETAINING RING, BC-CS			1		
8	11	962103-7	RETAINING RING			1		
8	12	922241-7	HEX. SOCKET HEAD BOLT			1		
8	13	265590-2	+HEX.BOLT WITH R			1		
8	14	187547-2	CUTTER SHAFT SET			1		
8	14	188902-1	CUTTER SHAFT SET			1		
8	15	210115-7	BALL BEARING			1		
8	16	962106-1	RETAINING RING			1		
8	17	331861-0	RECEIVE WASHER			1		
8	18	346660-7	CLAMP WASHER			1		
8	18	346084-7	CLAMP WASHER			1		
8	19	168526-9	SLIDING CUP			1		
8	20	264025-0	HEX NUT			1		
8	21	451097-6	PROTECTOR COVER			1		
8	22	266579-3	HEX. SOCKET HEAD BOLT			2		
8	23	346073-2	PROTECTOR CLAMP			1		
8	24	413143-3	WASHER			2		
8	25	452260-4	PROTECTOR			1		
8	26	266326-2	SCREW			1		
8	27	346074-0	LINE CUTTER			1		
8	28	135398-7	PROTECTOR EXTENSION ASSY			1		