



Microchip PIC10/12/16/18 (ICSP) Mass ISP Programming

Application Note

DC04024

NanoPlex™ general description

NanoPlex NPS-06-01-04A Universal Relay ISP-Channel Multiplier allows the expansion of the number of channels of ISP-Programming tools, while also offering galvanic isolation. The total number of switched signals is 28. NanoPlex is used on PCBAs production lines, in ATE-controlled ISP programming. Thanks to its ultra-small size (only 51.0- x 66.5-mm), this NanoPlex model takes easily place in Test Fixtures. Designed for piggyback mounting, NanoPlex is universal and compatible with all types of ISP Programming tools.

Recommended Readings - Further Documentation

Before starting, please study the following essential papers:

- *NanoPlex NPS-06-01-04A Data Sheet*
- *NanoPlex NPS-06-01-04A Flexibility Application Note*

'*NanoPlex NPS-06-01-04A Flexibility Application Note*' clearly describes NanoPlex **modularity** and how to deploy **multiple units** in order to create high-density ISP Programming Multipliers with an **unlimited number of channels**.

Microchip PIC10/12/16/18 (ICSP)

Signals required for ISP Programming are:

- ICSPDATA
- ICSPCLK
- MCLR
- PGM
- Vdd (optional)

The most convenient way to ISP program multiple instances of this device through NanoPlex is using this model in **1x4 operating mode**. 1 NanoPlex input channel is multiplied to 4 separated, galvanic isolated output channels.

On the following mode examples diagram, NanoPlex signal names are assigned with aliases (texts are in **bold**).

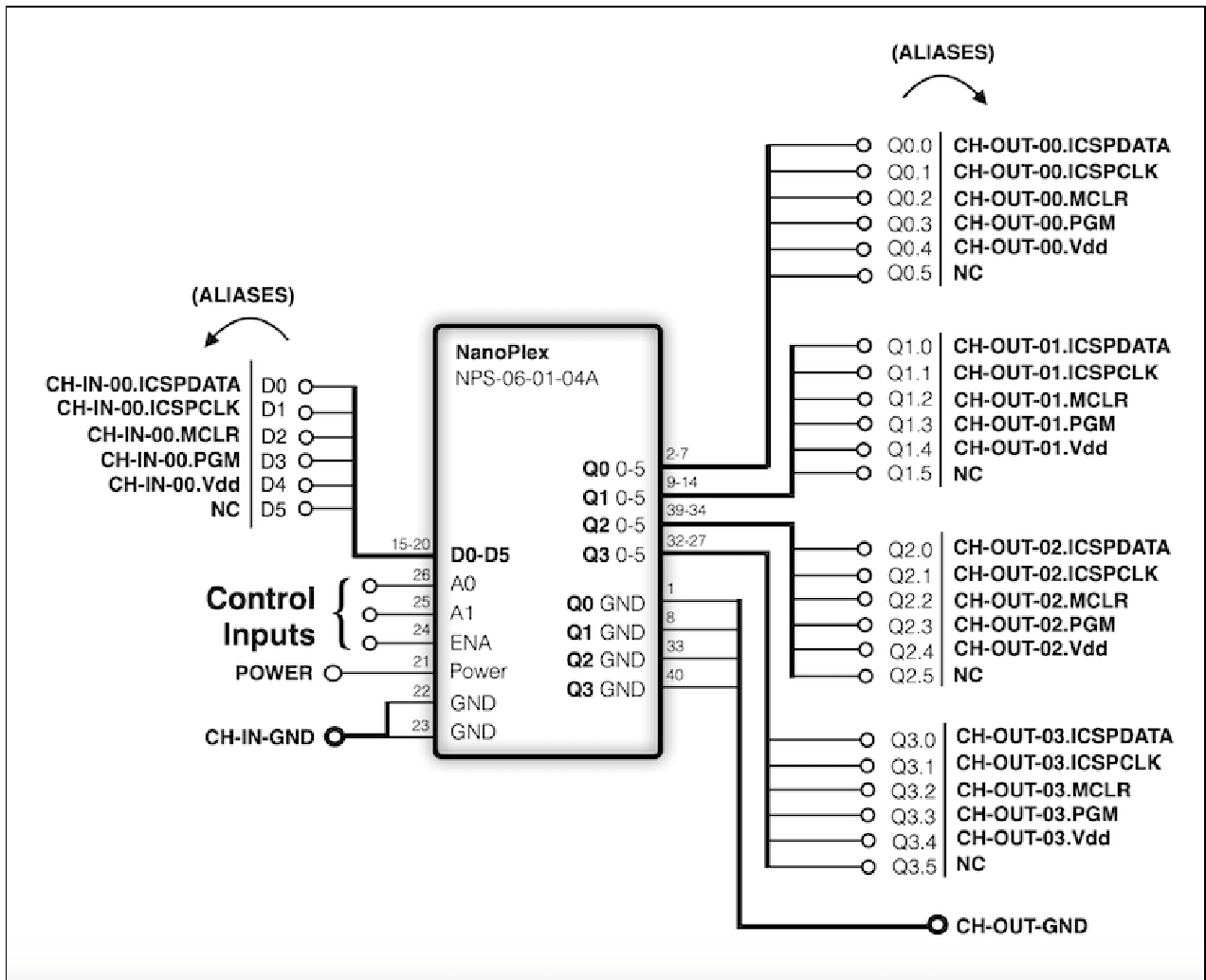

Truth table

(the symbol ► stands for “connected to”)

ENA	A1	A0	CH-IN-	00.ICSPDATA	00.ICSPCLK	00.MCLR	00.PGM	00.Vdd
				►	►	►	►	►
1	0	0	CH-OUT-	00.ICSPDATA	00.ICSPCLK	00.MCLR	00.PGM	00.Vdd
1	0	1	CH-OUT-	01.ICSPDATA	01.ICSPCLK	01.MCLR	01.PGM	01.Vdd
1	1	0	CH-OUT-	02.ICSPDATA	02.ICSPCLK	02.MCLR	02.PGM	02.Vdd
1	1	1	CH-OUT-	03.ICSPDATA	03.ICSPCLK	03.MCLR	03.PGM	03.Vdd
0	X	X	CH-OUT-	HI-Z	HI-Z	HI-Z	HI-Z	HI-Z

Operating sequence

ENA = 1

A1-A0 = "00"

CH-IN-00.ICSPDATA	▶	CH-OUT-00.ICSPDATA
CH-IN-00.ICSPCLK	▶	CH-OUT-00.ICSPCLK
CH-IN-00.MCLR	▶	CH-OUT-00.MCLR
CH-IN-00.PGM	▶	CH-OUT-00.PGM
CH-IN-00.Vdd	▶	CH-OUT-00.Vdd

A1-A0 = "01"

CH-IN-00.ICSPDATA	▶	CH-OUT-01.ICSPDATA
CH-IN-00.ICSPCLK	▶	CH-OUT-01.ICSPCLK
CH-IN-00.MCLR	▶	CH-OUT-01.MCLR
CH-IN-00.PGM	▶	CH-OUT-01.PGM
CH-IN-00.Vdd	▶	CH-OUT-01.Vdd

A1-A0 = "10"

CH-IN-00.ICSPDATA	▶	CH-OUT-02.ICSPDATA
CH-IN-00.ICSPCLK	▶	CH-OUT-02.ICSPCLK
CH-IN-00.MCLR	▶	CH-OUT-02.MCLR
CH-IN-00.PGM	▶	CH-OUT-02.PGM
CH-IN-00.Vdd	▶	CH-OUT-02.Vdd

A1-A0 = "11"

CH-IN-00.ICSPDATA	▶	CH-OUT-03.ICSPDATA
CH-IN-00.ICSPCLK	▶	CH-OUT-03.ICSPCLK
CH-IN-00.MCLR	▶	CH-OUT-03.MCLR
CH-IN-00.PGM	▶	CH-OUT-03.PGM
CH-IN-00.Vdd	▶	CH-OUT-03.Vdd

Connector pinout (aliases signals, top view)

Pin	Signal
01	CH-OUT-GND
02	CH-OUT-00.ICSPDATA
03	CH-OUT-00.ICSPCLK
04	CH-OUT-00.MCLR
05	CH-OUT-00.PGM
06	CH-OUT-00.Vdd
07	NC
08	CH-OUT-GND
09	CH-OUT-01.ICSPDATA
10	CH-OUT-01.ICSPCLK
11	CH-OUT-01.MCLR
12	CH-OUT-01.PGM
13	CH-OUT-01.Vdd
14	NC
15	CH-IN-00.ICSPDATA
16	CH-IN-00.ICSPCLK
17	CH-IN-00.MCLR
18	CH-IN-00.PGM
19	CH-IN-00.Vdd
20	NC

Signal	Pin
CH-OUT-GND	40
CH-OUT-02.ICSPDATA	39
CH-OUT-02.ICSPCLK	38
CH-OUT-02.MCLR	37
CH-OUT-02.PGM	36
CH-OUT-02.Vdd	35
NC	34
CH-OUT-GND	33
CH-OUT-03.ICSPDATA	32
CH-OUT-03.ICSPCLK	31
CH-OUT-03.MCLR	30
CH-OUT-03.PGM	29
CH-OUT-03.Vdd	28
NC	27
A0	26
A1	25
ENA	24
GND (*)	23
GND (*)	22
Power	21

(*) GND at pins 22/23 is used for both Power GND and CH-IN-GND.

Using multiple NanoPlex NPS-06-01-04A units

NanoPlex NPS-06-01-04A product is modular by design. Several units can be deployed in order to set-up a very large, limitless channel-multiplier. The advantage of using more units is a faster and less expensive substitution.

Please read '[NanoPlex NPS-06-01-04A Flexibility Application Note](#)' to discover how to set-up a switching system with the **number of channels as high as your application requires**.

About Manta Systems

Manta Systems is a high-tech company, global leader in high-density signal switching for In-System Programming (ISP) and Testing Systems. The company targets the electronic boards assembly market, where a high number of connections is required. Manta Systems flagship product is NanoPlex™, a series of Channels Multipliers for In-System Programming (ISP) and Testing instruments. NanoPlex is the **world's first universal tool** providing end-user with the possibility of having compact, easy-to-use, professional, reliable In-System Programming (ISP) and Testing Channel Multiplication functionality.

Warranty

All Manta Systems products are covered by a **three-year warranty** against defects and workmanship from the purchase date. The warranty only covers products when properly installed and used.

Orders

All NanoPlex™ Series products are generally **off-the-shelf**.

Shipping is within **24 hours** from order reception.

Free shipping & 30-day money back guarantee.

Disclaimer

Manta Systems is the owner of NanoPlex™ tradename. Manta Systems reserves the right to make improvements to NanoPlex™ Series and its documentation without notice. Information in this document is intended to be accurate and reliable. However, Manta Systems assumes no responsibility for its use; nor for any infringements of rights of third parties which may result from its use.

MANTA SYSTEMS WILL NOT BE LIABLE FOR DAMAGES RESULTING FROM LOSS OF DATA, PROFITS, USE OF PRODUCTS, OR INCIDENTAL OR CONSEQUENTIAL DAMAGES, EVEN IF ADVISED OF THE POSSIBILITY THEREOF.

Copyright © Manta Systems. All rights reserved.

NanoPlex™ is a tradename of Manta Systems.

All other product or service names are the property of their respective owners.

www.mantasys.com

info@mantasys.com

