

JARDAN

Wilbur

Assembly Instructions

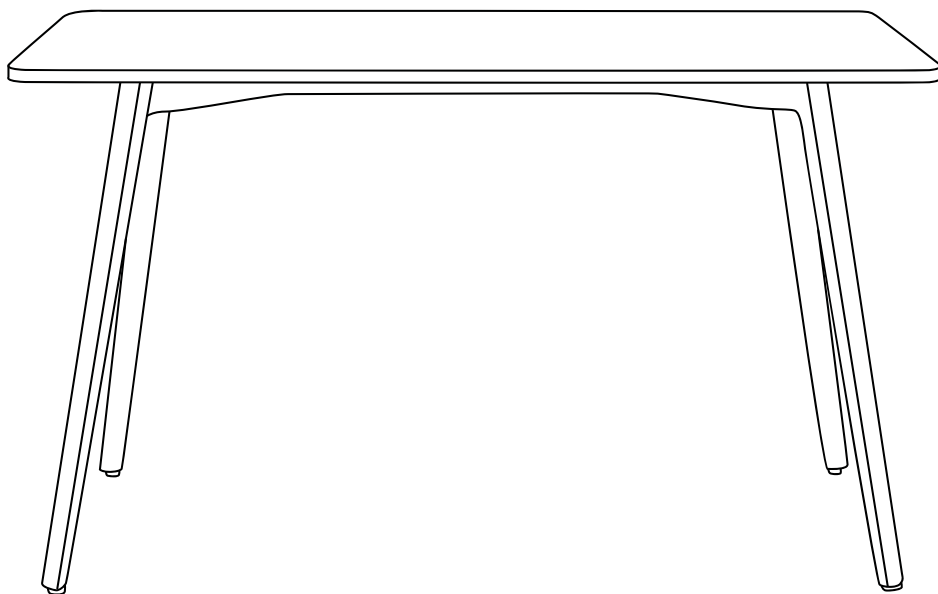

3 Leg / 4 Leg

jardan.com.au

JARDAN

Wilbur Assembly Instructions

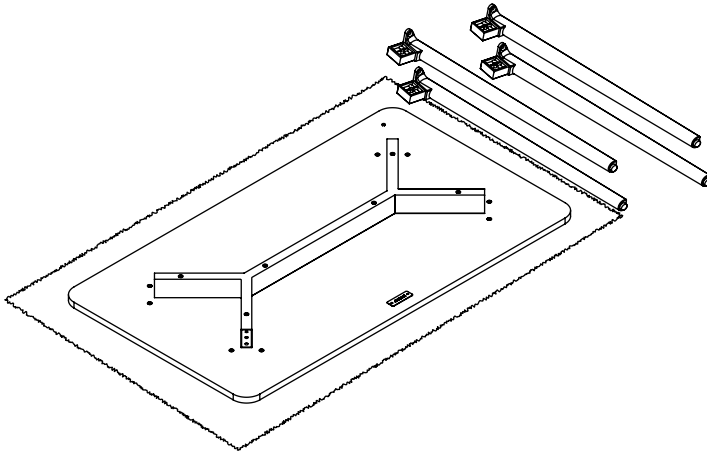

- 1** Place the worktop face down on soft surface.

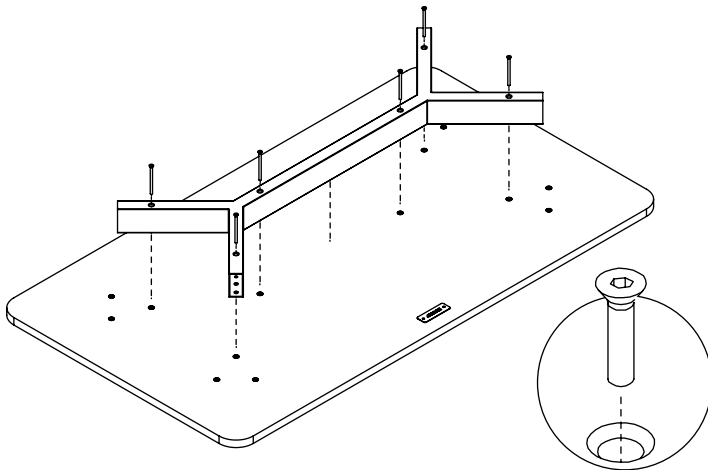

- 2** Unscrew and remove long bolts from the frame. Lift off frame from top and place frame on soft surface.

JARDAN

Wilbur Assembly Instructions

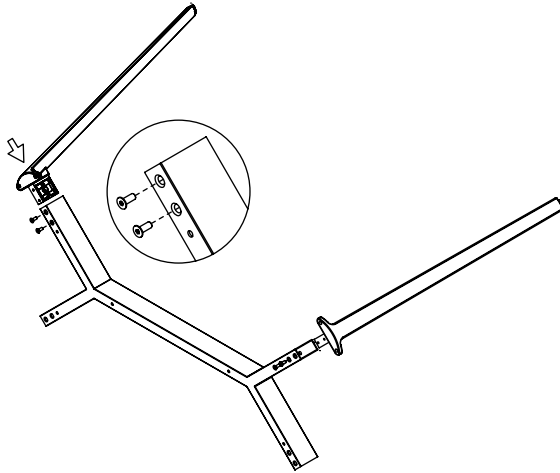

- 3** Stand the frame on its side and insert leg bracket into tube. Use provided 2x M6x16 countersunk screw to securely fix leg in place. Repeat process with next leg.
-

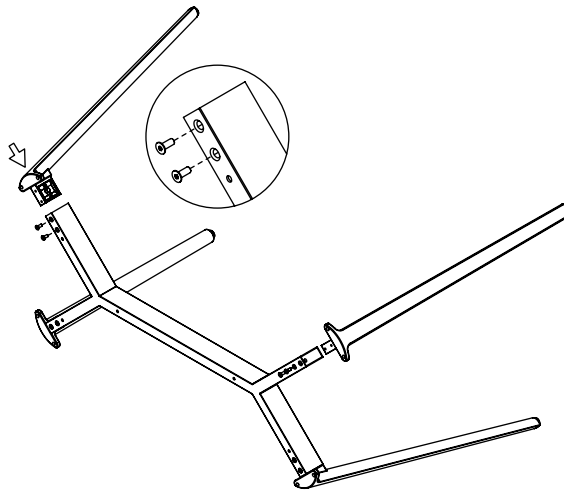

- 4** Flip frame over and insert leg bracket into tube. Use provided 2x M6x16 countersunk screw to securely fix leg in place. Repeat process with next leg.
-

JARDAN

Wilbur Assembly Instructions

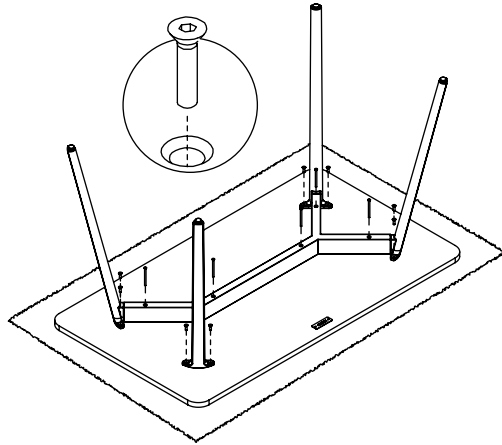

- 5** Place assembled frame back onto the underside of the face down work top. Use the long M6x70 screws to secure the frame to the top. Use Remaining M6x16 screws to fix legs to worktop. Tighten all screws.

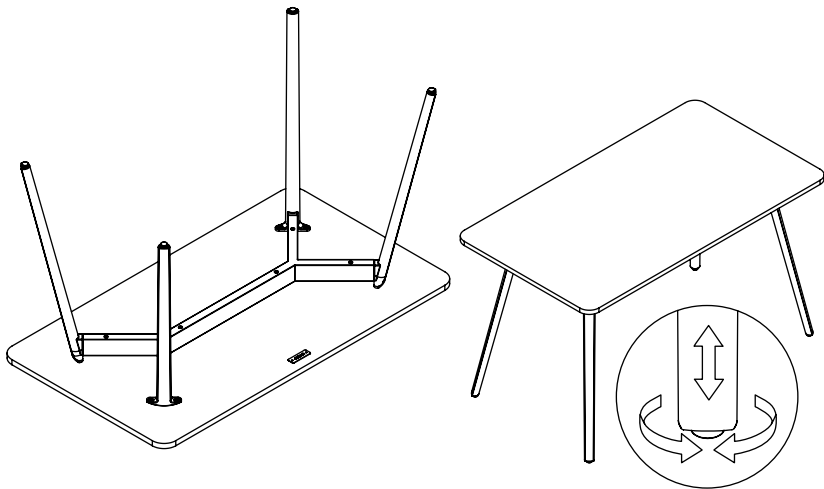

- 6** Safely flip table right side up. Twist glides at the base of the legs to level table if required. Note: Use more than one person to flip/move table.

JARDAN

Care and Maintenance

Our philosophy is simple, we only make furniture that lasts. Over their lifetime our products will need a little care and attention to ensure they can be enjoyed by generations to come. The following information will help you care for your Jordan products in the best possible way.

Laminate

For general care and maintenance, simply wipe away most spills or marks with a damp cloth, or use an all purpose cleaner such as Windex spray cleaner or Ajax Spray n Wipe. Rubbing gently with a clean, dry cloth brings back the brightness of laminates. Avoid contact with abrasive materials, waxes, polishes, bleach and strongly acidic or alkaline cleaners as these may damage the surface. Contact with a direct heat source should also be avoided.

Timber Oil Finish

Timber is a natural product that will respond to its environmental conditions. For timber products with an oil finish we recommend that you pay particular attention to protecting the piece from hot or wet objects. Do not leave liquid to sit on timber surfaces as it will penetrate the surface and cause staining. Wipe up spills immediately with a damp cloth.

Dependant on the position of the piece and the conditions of your home, we recommend re-oiling once a year. We advise having your furniture re-oiled at least once by our professional craftspeople to learn the correct application techniques. In some cases, an additional application may be required after the first six months. Oil care packages are available from your nearest Jordan store.

Do not use any other cleaners or polishes as they may permanently damage your furniture. Slab or underfloor heating can be damaging to solid timber products. The heat causes the bottom side to dry out differently to the top which can cause bowing, warping or cracking. We advise that you do not keep solid timber pieces on underfloor heating.

Powdercoated Metal

Regularly wipe metal with a damp soft cloth to remove particles which can abrade the surface with wear. Avoid contact with liquid, heat and direct sunlight. Abrasive cleaning products are not recommended.

Contact

For more information visit our website. If you can't find what you're looking for our friendly sales team will be happy to help, contact your nearest Jordan store.

jordan.com.au
