

JARDAN

Lewis Bed

Assembly Instructions

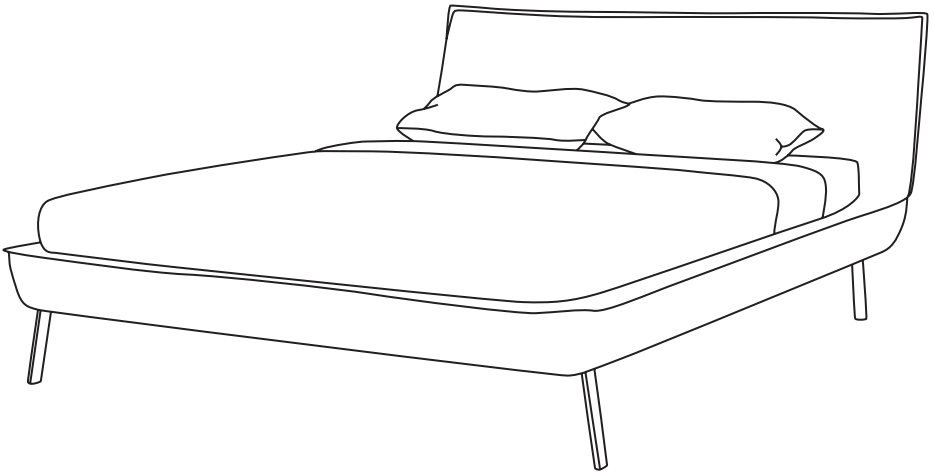

Lewis Bed

jardan.com.au

JARDAN

Lewis Assembly Instructions

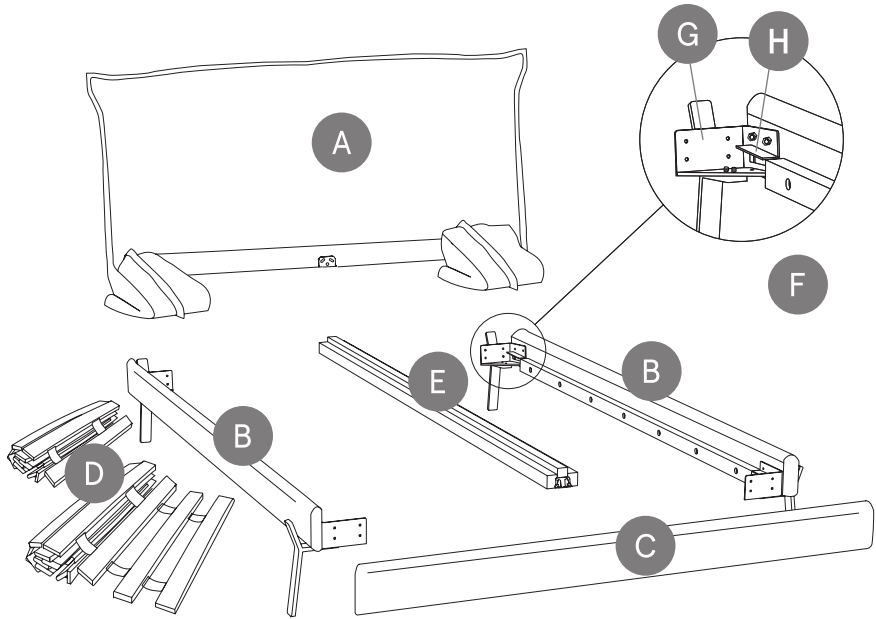

Components

Required

A 1 x Headboard	1 x Cordless Torque Drill on low setting (to prevent damage)
B 2 x Side rails	1 x 5/16 Hex nut socket drive
C 1 x Foot rail	1 x 5/16 Spanner
D 1 x Center rail	2 x People (minimum)
E 4 x Slat supports	
F 2 x Slat rolls	
G 16 x Hex head screws	
H 4 x Corner brackets	

JARDAN

Lewis Assembly Instructions

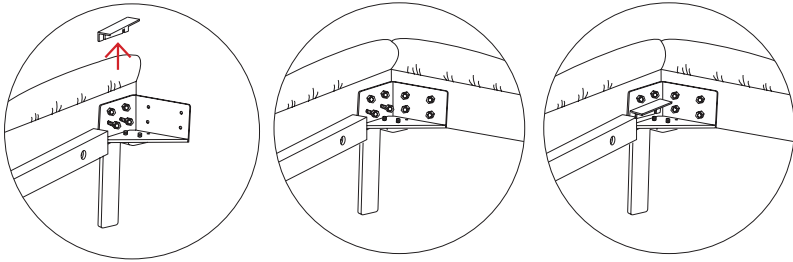

Unwrap and familiarise yourself with all the components. Both the side rails B will have legs, corner brackets G and slat supports H pre-fixed at each end. Align components as shown in figure 1. Loosen the screws which fasten each slat support H to the corner bracket G until each slat support can be slid out of place. Take note of each slat supports location as they are directional. Fasten the foot rail C to the side rails B by screwing through the corner brackets. Use a 5/16 spanner to reach any screws you can't access with a drill.

1

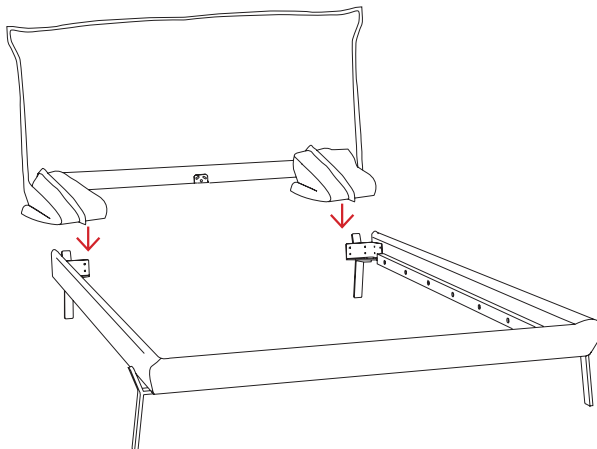

2 Once the foot rail C is fixed in place, slide the slat supports H back into place and tighten screws. The frame should now be standing. Lower the headboard into place between the legs and corner brackets, repeating steps 2-4 until secure.

JARDAN

Lewis Assembly Instructions

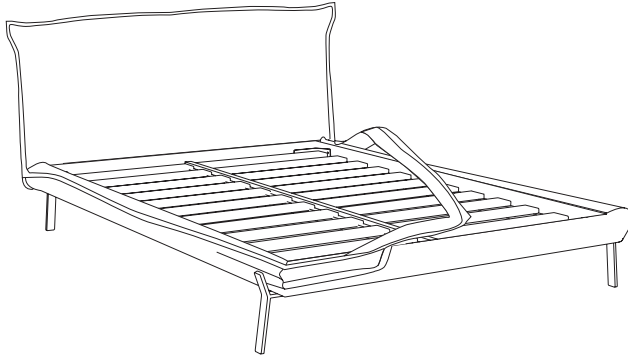

3

Lower the center rail E onto the bed frame until it locks into the central attachments on the headboard A and foot rail C. Roll out the slat rolls, securing in place at each end using the velcro attachments. Pull the loose cover over the foot rail at each corner by compressing the foam until the fabric cover slides over the top. Straighten the cover so the pinched edge runs straight along the edges of the frame.

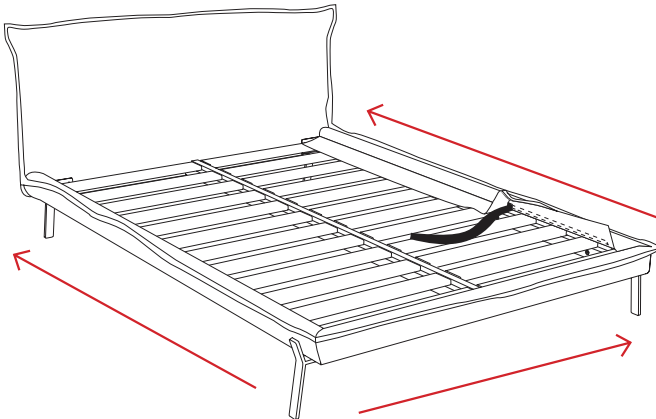

4

Secure the cover in place by removing the protective strips from the velcro, working from corner to corner as pictured. Repeat to secure the cover to the underside of the bed, ensuring corners are in place and cover is in between leg and bed.

JARDAN

Care and Maintenance

Our philosophy is simple, we only make furniture that lasts. Over their lifetime our products will need a little care and attention to ensure they can be enjoyed by generations to come. The following information will help you care for your Jordan products in the best possible way.

Fabric

Vacuum fabrics on a weekly basis to remove dust, dirt and any loose feathers. Treat spills and stains as soon as possible by wiping with a damp cloth, do not treat with chemical cleaners or scrub as this can alter the fabrics appearance. We recommend contacting a specialist fabric cleaner to treat difficult stains. To prolong the life of your upholstery, we recommend annual cleaning by a specialist fabric cleaner. Direct sunlight may cause colour change and aging of your fabric, for best performance we recommend positioning your furniture out of direct UV light. Please refer to the Materials Library on our website for care information specific to your fabric.

Powercoat Metal

Regularly wipe metal with a damp soft cloth to remove particles which can abrade the surface with wear. Avoid contact with liquid, heat and direct sunlight. Abrasive cleaning products are not recommended.

Contact

For more information visit our website. If you can't find what you're looking for our friendly sales team will be happy to help, contact your nearest Jordan store.

jordan.com.au
